

Name:

Yacht:

Kontakt:



SPINNAKER/
GENNAKER

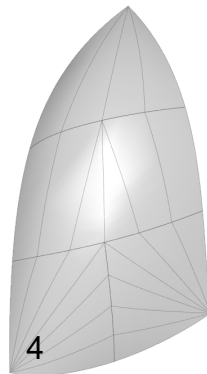
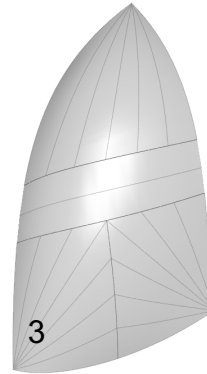
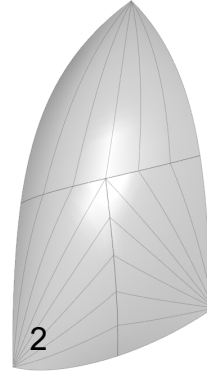
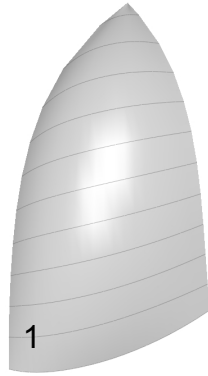
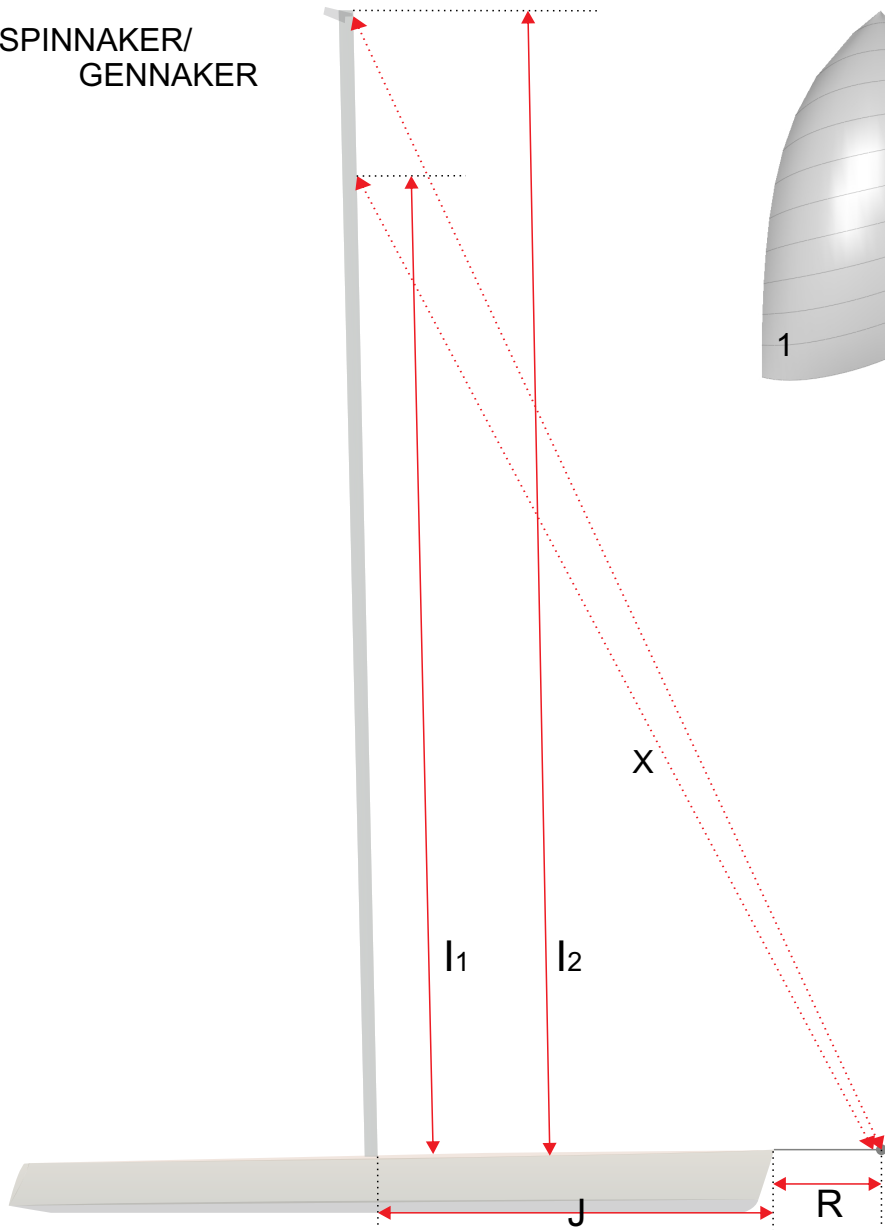

| | |
|--|--|
| I1 oder I2 | |
| J | |
| R | |
| X (Anschlagpunkt Hals bis Fallauslass) | |
| Schnitt (1 - 4) | |

| | |
|---|--|
| Segeltyp (Gennaker oder Spinnaker, Cruising oder Racing, für welchen Wind) | |
| Look (Farben) | |

Anmerkungen:

| |
|--|
| |
|--|